



MODULAR 3-WAY VALVES

R-311



Description:

R-311 is a 3-way, spring return, fully ported valve with four pilots. Any one of the four pilots will actuate the valve. Actuating more than one pilot has no additional effect. Pilot signals must be absent at all four pilots to release the valve. The valve can be used Normally-Open, Normally-Closed, as a selector or as a diverter, all with four pilot inputs. It can also be used as a 2-way valve by plugging the exhaust ports. The R-311 may be used to replace an R-301 or R-321 valve in a circuit when additional pilot inputs are required. The R-311 also features an auxiliary pilot on the spring side of the valve. The auxiliary pilot will overcome any one or all of the four input pilots.

3-Way Multiple Pilot Valve

Features:

- Indicator shows valve in shaded position
- Multiple pilots reduces number of valves - reduces piping and space required
- Micro gap construction - snap action and no blow by
- Balanced design allows speed control at exhaust

Performance:

Flow: 9 scfm @ 100 psig; 255 l/min @ 6.9 bars

Pilot Pressure Minimum: 40 psig; 2.8 bars

Temperature: 32 to 180°F

Working Pressure: 0 to 150 psig; 0 to 10.3 bars

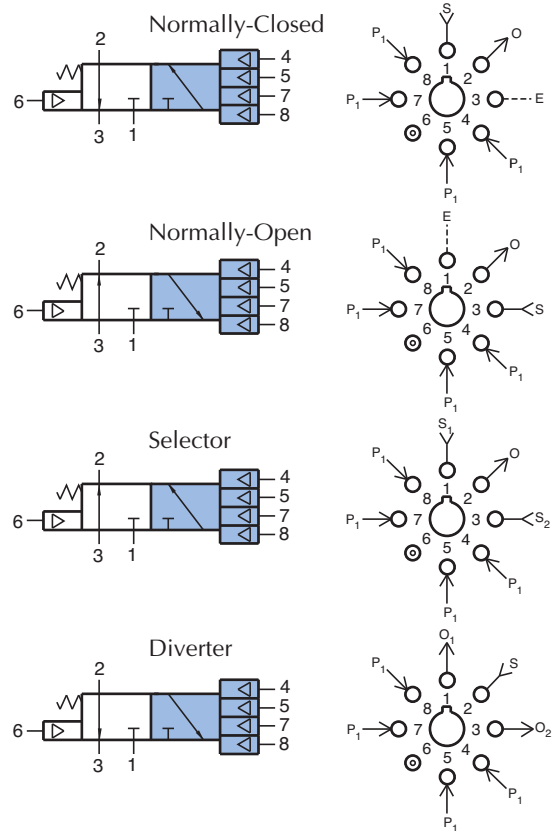

R-312



Description:

R-312 is a 3-way, two position, fully ported valve with four pilots on one position. Any one of the four pilots on one position will actuate the valve. Actuating more than one pilot has no additional effect. Pilot signals must be absent at all four pilots before the opposite pilot can shift the valve. The valve can be used Normally-Open, Normally-Closed, as a selector, or as a diverter, all with four pilot inputs. It can also be used as a 2-way valve by plugging the exhaust ports. The R-312 may be used to replace an R-302 or R-322 valve in a circuit when additional pilot inputs are required.

3-Way Multiple Pilot Valve

Features:

- Indicator shows valve in shaded position
- Multiple pilots reduces number of valves - reduces piping and space required
- Micro gap construction - snap action and no blow by
- Balanced design allows speed control at exhaust

Performance:

Flow: 9 scfm @ 100 psig; 255 l/min @ 6.9 bars

Pilot Pressure Minimum: 20 psig; 1.4 bars

Temperature: 32 to 180°F

Working Pressure: 0 to 150 psig; 0 to 10.3 bars

